

CONTACT JOINT WITH KEYWAY AND TIE BAR

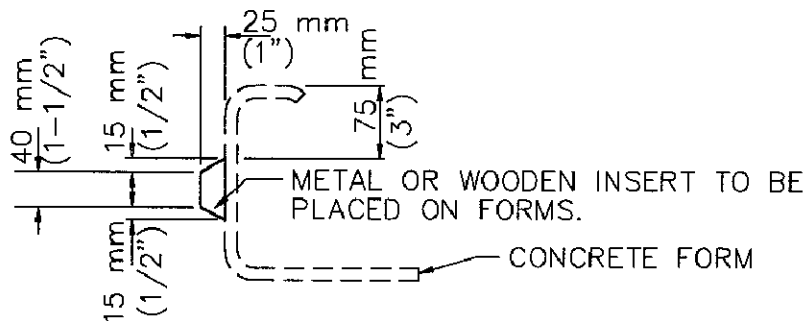

KEYWAY INSERT DETAIL

NOTES:

1. LONGITUDINAL JOINTS SHALL BE LOCATED AS SHOWN ON PLAN. CONTACT OR WEAKENED PLANE JOINTS MAY BE USED AT THE CONTRACTOR'S OPTION.
2. TRANSVERSE WEAKENED PLANE JOINTS SHALL BE CONSTRUCTED AT INTERVALS OF 4500 mm (15') AND SHALL BE AT LEAST 1500 mm (5') FROM ANY TRANSVERSE CONTACT JOINT. (SEE NOTE 5.)
3. TRANSVERSE CONTACT JOINTS SHALL BE CONSTRUCTED AS SHOWN HEREON AT ALL CONSTRUCTION JOINTS AND AS DIRECTED BY THE ENGINEER.
4. SPACE TIE BARS AT 1000 mm (36") ON CENTER FOR TRANSVERSE JOINTS AND 1200 mm (45") FOR LONGITUDINAL JOINTS. PLACE IN MIDDLE THIRD OF SLAB.
5. SEE SUBSECTION 302-6.5 OF SSPWC FOR DETAILS ON CONCRETE PAVEMENT JOINTS.
6. CONSTRUCT CONTACT JOINTS IN THE APPROACH SLABS AT THE FIRST THREE TRANSVERSE JOINTS OF CONCRETE INTERSECTIONS.
7. DIMENSIONS SHOWN ON THIS PLAN FOR METRIC AND ENGLISH UNITS ARE NOT EXACTLY EQUAL VALUES. IF METRIC UNITS ARE USED, ALL VALUES USED FOR CONSTRUCTION SHALL BE METRIC VALUES. IF ENGLISH UNITS ARE USED, ALL VALUES USED FOR CONSTRUCTION SHALL BE ENGLISH VALUES. HOWEVER, ASTM 615 REINFORCING STEEL MAY BE SUBSTITUTED FOR ASTM 615M STEEL.

AMERICAN PUBLIC WORKS ASSOCIATION - SOUTHERN CALIFORNIA CHAPTER

PROMULGATED BY THE
PUBLIC WORKS STANDARDS INC.
GREENBOOK COMMITTEE
1993
REV. 1996

CONCRETE PAVEMENT JOINT DETAILS

USE WITH STANDARD SPECIFICATIONS FOR PUBLIC WORKS CONSTRUCTION

STANDARD PLAN
METRIC

134 - 1

SHEET 1 OF 1